

GLORIA®

SPRAYERS FOR ALL REASONS



TOP QUALITY PRODUCTS – SERVICE YOU CAN TRUST

GLORIA Heavy Duty Compression Sprayers

OPERATING INSTRUCTIONS & SPARE PARTS LIST

'SPECIAL' - VITON SEAL VERSIONS

These are high specification sprayers, suitable for applying a wide variety of sprayable products. There are however, many liquids which are either not safe to be sprayed, or which may damage your sprayer. Acid and alkaline (caustic) chemicals should not be used in these sprayers; they can cause premature corrosion failure of most metal components. If in doubt concerning a chemicals' safety or compatibility, please consult the chemical manufacturer before using it.

PLEASE READ THIS LEAFLET THOROUGHLY AND KEEP IT FOR FUTURE REFERENCE. FOLLOW THE INSTRUCTIONS CAREFULLY AND OBSERVE THE RULES BELOW FOR SAFER SPRAYING

- **ALWAYS** use personal protection equipment as recommended by the manufacturer of the chemical you are applying, i.e. gloves, faceshield, respirator, coveralls etc.
- **NEVER** eat, drink or smoke whilst dealing with spray chemicals, until after you have removed any protective clothing and washed your hands thoroughly.
- **ALWAYS** check the condition of the sprayer, especially security of joints and connections before each use. Proper operation of the relief valve should also be checked regularly - See relief valve testing under MAINTAINING THE SPRAYER.
- **NEVER** mix chemicals unless recommended by the chemical manufacturer.
- **ALWAYS** read and follow the chemical manufacturers instructions.
- **NEVER** mix more chemical than you will need to use at one application.
- **ALWAYS** use genuine GLORIA parts to repair the sprayer.
- **NEVER** attempt to clear a blocked spray nozzle by blowing through it with your mouth.
- **NEVER** leave the sprayer exposed to hot sun.
- **NEVER** store spray chemical in the sprayer.
- **ALWAYS** avoid spraying in windy weather.
- **ALWAYS** release the pressure, empty and clean the sprayer thoroughly after each use.

| TECHNICAL SPECIFICATIONS: | 141T | 176T | 142T | 172RT |
|----------------------------|--|--------------------------------|-----------------|------------------|
| Working capacity | 5 litres | 5 litres | 10 litres | 10 litres |
| Total capacity | 8 litres | 8 litres | 13.7 litres | 13.7 litres |
| Maximum operating pressure | All models | 6 bars (90psi) | | |
| Maximum operating temp. | All models | + 50 deg. C | | |
| Safety features | All models | Pressure gauge Relief valve | | |
| Container material | Stainless steel | Galvanised steel | Stainless steel | Galvanised steel |
| Seal material | All models | Viton | | |
| Spray nozzle | Either variable type, adjustable from a 0 degree pencil jet, to 60 degree, hollow conespray pattern, or GPS Universal Nozzle Holder with specific, fixed spray pattern, interchangeable spray tip. | | | |

PREPARING THE SPRAYER

- 1 Attach the end of the hose into the container outlet with the spanner provided.
- 2 Screw the spray lance onto the trigger valve.
- 3 Fit the carrying strap(s) as per diagrams opposite; diagram A is for the 176T/172RT, diagram B is for the 141T/142T and diagrams C and D are for the 142T/172RT.
- 4 Test the sprayer with water, following instructions 1a to 6a under "OPERATING THE SPRAYER".

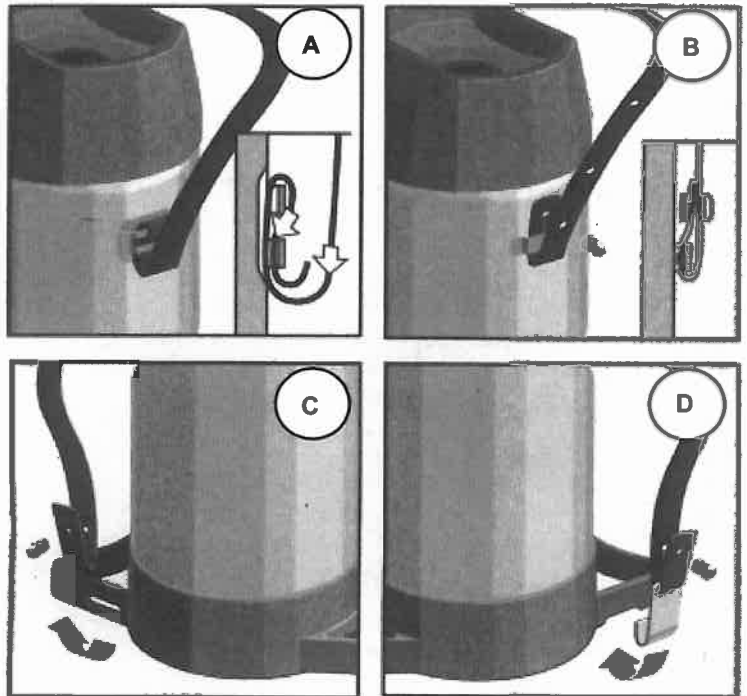

OPERATING THE SPRAYER

The 'D' handle on top of the pump is designed to carry the sprayer if you don't wish to put it on your back, or shoulder. To lock the handle in position, hold it down and turn it clockwise until the hooks on the handle locate on the two lugs on the pump barrel.

- 1a Before removing the pump, always ensure that the container is not pressurised, by holding down the red decompression button until no further air can be heard escaping.

Take care also, to remove any particles which may have accumulated in the filler funnel during storage, to prevent them falling into the container and causing blockages.

- 2a **Always unscrew the pump assembly very slowly at first allow any remaining pressure to escape safely.** To unscrew it, hold down the pump handle and turn it anti-clockwise against the lugs on the pump barrel.
- 3a Measure and pour in water, up to but not more than, the nominal working capacity of the sprayer. (5 litres or 10 litres)
- 4a Replace the pump assembly (do not overtighten) and operate it until the pressure gauge indicates that a suitable working pressure has been achieved. Over pumping will result in the safety relief valve operating and air will be heard escaping. If this occurs, cease pumping immediately.

See Testing the Safety Relief Valve under "MAINTAINING AND LUBRICATING THE SPRAYER".

OPERATING THE SPRAYER cont'd

- 5a Operate the on/off trigger control valve a few times until a satisfactory spray pattern occurs. (Immediate shut-off may not occur until all air has been expelled from the system).
- 6a Providing there are no leaks, the sprayer is now ready for use.

EMPTYING & CLEANING THE SPRAYER

- 1b Release any remaining pressure as described at 1a under "OPERATING THE SPRAYER".
- 2b Unscrew and remove the pump assembly.
- 3b Empty out the remaining contents and dispose of them safely.
- 4b Refill the sprayer with an appropriate cleaning fluid, or a weak, lukewarm solution of detergent and water, replace the pump and shake the container carefully to dilute any remaining residue. To ensure that the hose, lance and nozzle are also thoroughly rinsed, pump in a little pressure and operate the trigger valve. Repeat the operation, until the sprayer is thoroughly clean.

Store the sprayer upside down, with the pump removed, so the container can dry.

MAINTAINING AND LUBRICATING THE SPRAYER

Maintenance and repairs should only be carried out by a competent person, using genuine GLORIA replacement parts. If in any doubt, please contact GPS Sprayers Ltd., UK Agent for GLORIA. We will be pleased to either supply parts or service the sprayer for a reasonable charge.

BEFORE COMMENCING ANY WORK ON THE SPRAYER, ALWAYS RELEASE ANY REMAINING PRESSURE FOLLOWING THE INSTRUCTIONS AT 1a & 2a UNDER "OPERATING THE SPRAYER".

REGULAR EXAMINATION

The entire sprayer should be thoroughly examined at frequent, regular intervals for evidence of corrosion, breakage or leaks. Any faulty component found should be replaced before using the sprayer again.

GENERAL LUBRICATION

Occasional lubrication of rubber seals and 'O' rings which move, will keep the sprayer functioning nicely. If parts which employ an 'O' ring seal are removed, a light smear of grease around the outside of the 'O' ring, before the part is replaced, will ensure they slide into place properly to make a good seal. Suitable lubricants are a light grease or petroleum jelly.

TO LUBRICATE THE PUMP

The piston "O" ring (58), accessed by unscrewing the pump cap (3) at the top of the pump and withdrawing the piston rod (1). It should be lubricated with petroleum jelly or a similar light grease, but only on its' external perimeter. The frequency of this operation will depend on usage, but experience will soon tell when excessive friction occurs and the "O" ring is dragging, making pumping difficult. A little lubricant on the piston rod will also make pumping easier.

TO LUBRICATE THE TRIGGER VALVE

If the trigger valve becomes stiff or sluggish to operate, it is necessary to lubricate the valve spindle and its' 'O' rings (66) & (67).

CLEANING THE FILTER IN THE TRIGGER VALVE

There is a filter (44) in the handle of the trigger valve to prevent nozzle blockages. The filter can be unscrewed from the brass valve body (46) for cleaning, after first unscrewing the filter barrel (43).

TESTING THE SAFETY RELIEF VALVE

The safety valve should be tested at frequent, regular intervals; every three months if the machine is used continuously, or every six months if only used periodically. Proceed as follows.

- 1) Ensure that the trigger valve is closed.
- 2) Fill the sprayer almost full with water to exclude nearly all the air inside.

- 3) Pressurise the sprayer using the pump until the relief valve opens. This should occur at between 6 and 7 bars (90-100 psi.)

If the valve is not heard to operate between these pressures, it must be replaced before the sprayer is used again.

REMOVING & REPLACING THE FILLER FUNNEL (17)

This is necessary to access the relief valve (70), decompression valve (62), or pressure gauge (37). After releasing the pressure, replace the pump, and pour near boiling water into the funnel, allowing it to stand for a couple of minutes to soften the plastic. With gloves on, tip out the water, remove the pump and pull off the filler funnel whilst holding the container base with your feet. To replace, immerse the funnel in very hot water for a few minutes, then with gloves on and a blunt screwdriver handy, offer it into position on the container and press it home with your thumbs onto the container neck. The screwdriver may be necessary to prise the last area of lip home.

HYDRAULIC TESTING

This test is essential to ensure that the container is in good condition and has not become weakened by corrosion or damage. Test at least once a year, more often if the sprayer is used continuously, or with aggressive chemicals. Test Equipment - It is recommended that an auxillary pump such as a bucket pump, or boiler test pump is used. A check valve should be installed in the pump outlet and connected directly to the container under test, via a suitable hose at least 10 metres long. A 14 bar pressure gauge and bleed-off valve should be connected downstream of the check valve. This valve will allow the container pressure to be released after testing.

Preparation - Carefully remove the funnel, relief valve, decompression valve and pressure gauge and replace them with test plugs. (Part No. 08-055 available from GPS Sprayers Ltd.) Connect the 10 metre hose to the container outlet and remove the sprayers' pump assembly.

Testing - Completely fill the container with water to exclude all air and replace the pump assembly. Thoroughly dry the outside of the container before testing, to allow possible leaks to show up. The container under test should be placed behind a protective screen and the auxillary pump operated at the full 10 metres distance provided by the hose. The container should be pressurised to 10 bars and the pressure maintained for at least 10 minutes. After testing, decompress by opening the bleed-off valve.

IMPORTANT - Failure to remove all air before performing the test could lead to explosive failure during testing.

Examination - Examine external surface for signs of leaks, especially at the seams. Remove test hose and empty the container. Remove the sprayer pump and use a light to examine internal seams for corrosion and distortion. If there is any doubt, even after the test, as to the soundness of the container, it should be replaced immediately.

TROUBLE SHOOTING

| SYMPTOM | POSSIBLE CAUSE | REMEDY |
|--|--|---|
| Pump is difficult to operate, or does not appear to be creating pressure. | Piston 'O' ring (58) is dry or damaged. | Lubricate or replace piston 'O' ring. |
| Piston rises after pumping. | Footvalve (60) damaged or dirty. | Replace footvalve assembly. |
| Pump is operating, but pressure is being lost from container. | Pump not screwed in tight. | Tighten pump carefully - BUT DO NOT OVERTIGHTEN. |
| | Pump sealing 'O' ring (59) damaged. | Replace pump sealing 'O' ring. |
| Container has pressure but will not spray. | Blocked strainer (44) in trigger valve, or blocked nozzle. | Remove and clean the strainer or nozzle by flushing with water. |
| Poor spray pattern, even though all strainers appear clear and there is pressure in the container. | Nozzle partially blocked, or damaged. | Remove and clean, or fit a new nozzle. Never use a metallic object to clean the nozzle, it will ruin the spray pattern and render it useless. |

INTERCHANGABLE, FIXED SPRAY PATTERN NOZZLES

Since the nozzle determines how the sprayed product is actually applied, it's obviously a most important part of the sprayer. Whilst adjustable nozzles, similar to those found on 'garden' sprayers are adequate for many applications, fixed spray pattern nozzles will usually achieve better results.

The most popular form of fixed spray pattern nozzle is an 'interchangeable nozzle tip', usually made of plastic or brass. There are literally thousands of these available, to provide an almost infinite variety of spray patterns and application rates.

The GPS Universal Nozzle Holder assembly, which screws either onto the end of the spray lance tube (15), or directly onto the trigger valve (46), is designed to accommodate any of these 'International standard' interchangeable nozzle tips (50). It usually incorporates a suitable strainer, to prevent nozzle blockages.

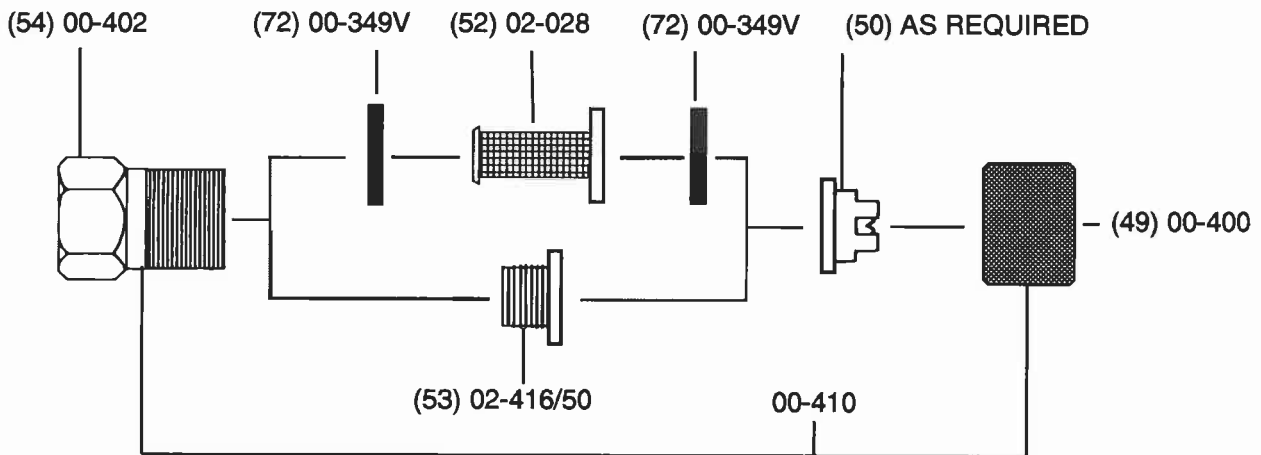

One strainer (52) has a fine, 100 mesh screen for protecting nozzle tips with small orifices and is used with the two rubber seals (72). Strainer (53) has a coarser, 50 mesh screen, suitable for nozzle tips with larger orifices and does not require rubber seals, because it is made from a softer material.

The Nozzle Body (54) and Nozzle Retaining Nut (49), are precision machined from brass. The two items are also available under one Part No. 00-410.

We stock around 65 different nozzle tips; our standard Nozzle Tip Selection Chart and advice regarding suitable nozzle tips for specific applications are available on request.

SOME ACCESSORIES FOR GLORIA HEAVY DUTY SPRAYERS

LANCE EXTENSIONS

These fit between the trigger valve and the sprayers' standard lance, to increase the working length by the extension length.

Brass fixed length extensions

| | |
|-----------|--------------------|
| 0.5 metre | Part No.124 |
| 0.7 metre | Part No.109 |
| 1.0 metre | Part No.110 |

Aluminium fixed length extensions

| | |
|-----------|--------------------|
| 1.5 metre | Part No 120 |
| 2.0 metre | Part No 123 |

Brass telescopic extensions

| | |
|-----------------|--------------------|
| 0.5 - 1.0 metre | Part No 131 |
| 1.0 - 2.0 metre | Part No 132 |

SPRAYCART TROLLEY

A handy two wheel trolley, to mobilise 5 or 10 litre GLORIA Heavy Duty Sprayers **Part No 198**

COMPRESSOR CONNECTOR

A unit resembling the head of the standard hand pump, but fitted with an additional relief valve and a 'schrader type' connector to facilitate charging the sprayer with a compressor. **Part No 135**

ALTERNATIVE HOSES

Different hose sizes, lengths, and material types, including small bore nylon surcoils and all necessary fittings, are readily available. **Details on request**

ALTERNATIVE SPRAY GUNS

Several options available **Details on request**

COMPONENT IDENTIFICATION - 'SPECIAL' - VITON SEAL VERSIONS

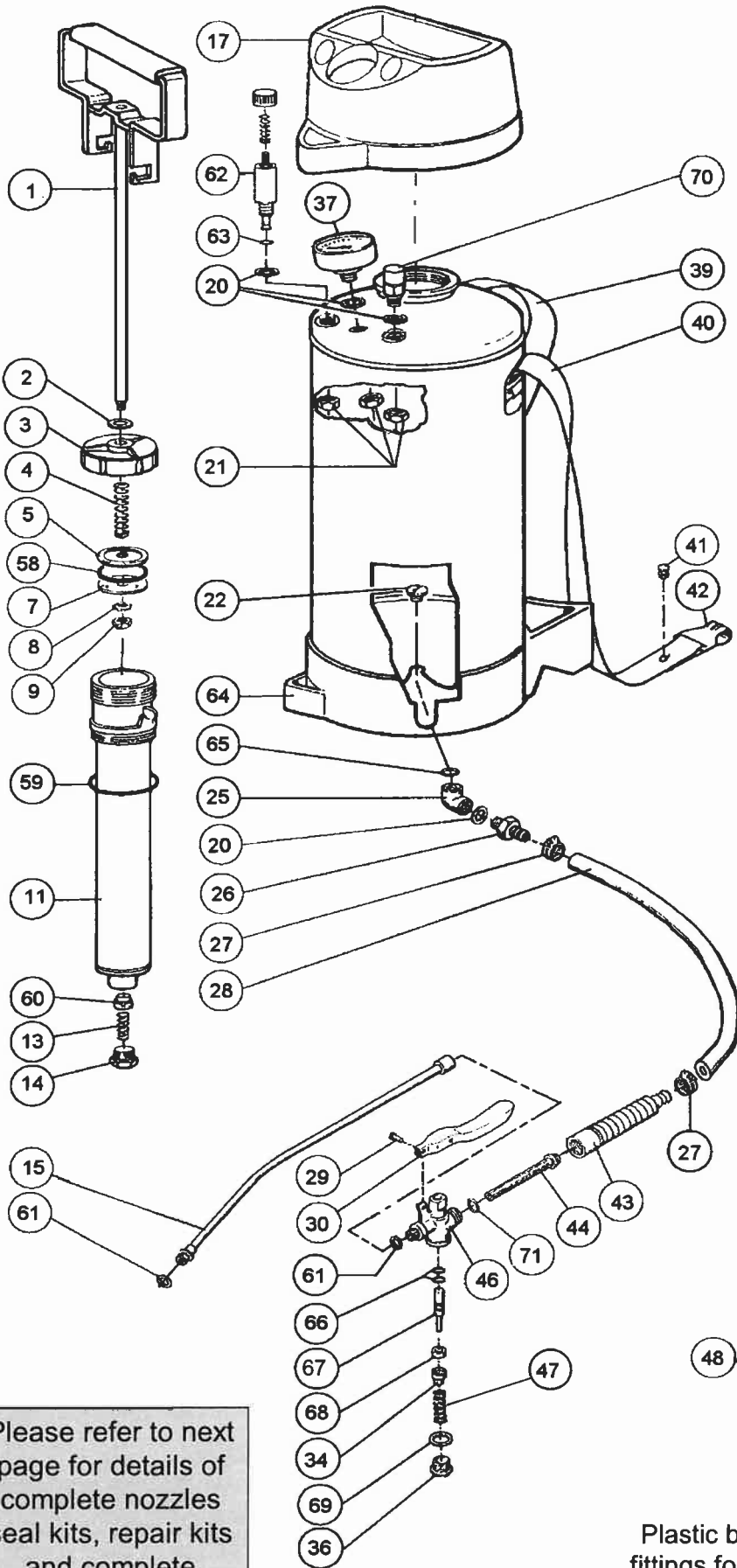

NOZZLES

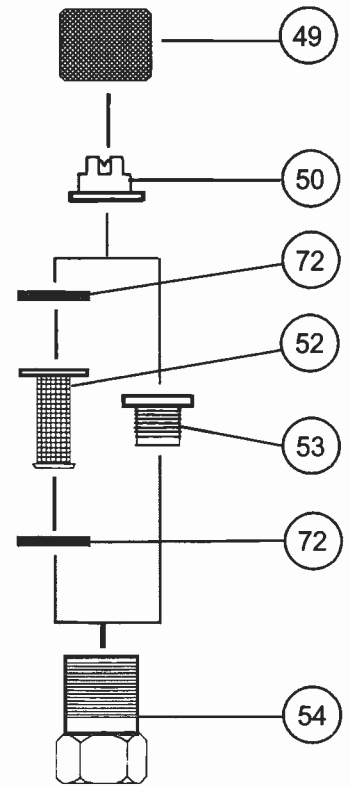

Universal Nozzle Holder

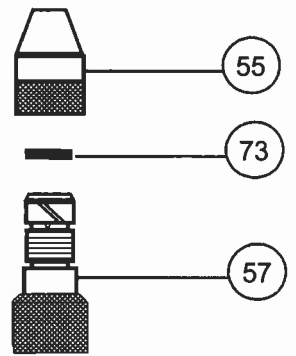

Adjustable Nozzle

Please refer to next page for details of complete nozzles seal kits, repair kits and complete assemblies.

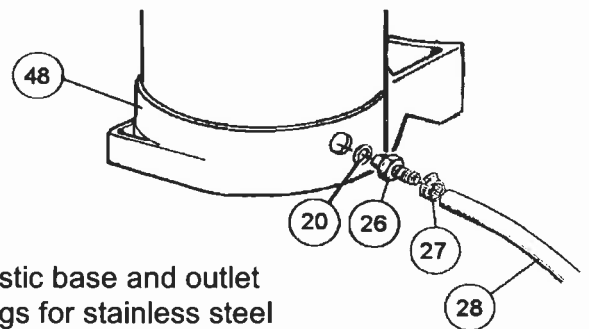

Plastic base and outlet fittings for stainless steel models 141T & 142T

COMPONENT PART DESCRIPTIONS - 'SPECIAL' - VITON SEAL VERSIONS

| Key | Part No. | Description | Key | Part No. | Description |
|-----|----------|----------------------------------|-----|-----------|-------------------------------|
| 1 | 709150 | Piston rod with handle - bare | 41 | 603060 | Stud for carrying strap |
| 2 | 611170 | Buffer washer for pump | 42 | 604410 | Hook for carrying strap |
| 3 | 605843 | Pump cap / piston guide | 43 | 511760 | Filter barrel for trigger |
| 4 | 610471 | Buffer spring for pump | 44 | 613320 | Strainer for trigger valve |
| 5 | 624230 | Piston plate - dished | 46 | 511820 | Body for trigger valve |
| 7 | 624330 | Piston plate - flat | 47 | 612071 | Spring for trigger valve |
| 8 | 200110 | Locking washer | 48 | 604420 | Black plastic base 141T |
| 9 | 634170 | Hexagon nut for piston rod | 48 | 604430 | Black plastic base 142T |
| 11 | 711210 | Pump barrel | 49 | 00-400 | Brass nut for nozzle holder |
| 13 | 615972 | Spring for footvalve | 50 | Various | Nozzle tip - please specify |
| 14 | 605000 | Retaining plug for footvalve | 52 | 02-028 | Nozzle strainer 100 mesh |
| 15 | 701310 | Lance tube with washer | 53 | 02-416/50 | Strainer 50 mesh blue P/P |
| 17 | 604240 | Black filler funnel 10 litre | 54 | 00-402 | Brass body for nozzle holder |
| 17 | 604250 | Blue filler funnel 10 litre | 55 | 601900 | Cap for adjustable nozzle |
| 17 | 604270 | Blue filler funnel 5 litre | 57 | 601920 | Body of adjustable nozzle |
| 17 | 604280 | Black filler funnel 5 litre | 58 | 625971 | Piston O ring |
| 20 | 618170 | Washer for gauge etc. | 59 | 503460 | Pump sealing O ring |
| 21 | 604500 | Hexagon nut for gauge etc. | 60 | 710870 | Footvalve poppet assembly |
| 22 | 538683 | Screw for container outlet | 61 | 603360 | Washer for lance and trigger |
| 25 | 538682 | Outlet adaptor elbow | 62 | 712090 | Decompression valve c/washer |
| 26 | 602800 | Tank outlet adaptor w/o washer | 63 | 604610 | O Ring for decomp'n valve |
| 26 | 712650 | Tank outlet adaptor c/w washer | 64 | 538752 | Black plastic base for 176T |
| 27 | 602900 | Worm drive hose clip | 64 | 538755 | Black plastic base for 172RT |
| 28 | 706950 | Hose 1.25 metres c/w clips | 65 | 130300 | O ring seal for outlet elbow |
| 29 | 633070 | Rivet for trigger lever | 66 | 503420 | O ring for trigger spindle |
| 30 | 600680 | Lever for trigger valve | 67 | 607472 | Valve spindle without O rings |
| 34 | 602570 | Housing for valve disc | 67 | 711790 | Valve spindle with O rings |
| 36 | 602370 | Base plug for trigger valve | 68 | 503410 | Rubber valve disc |
| 37 | 706410 | Pressure gauge, nut & washer | 69 | 503490 | Washer for base plug |
| 39 | 620140 | Strap c/w studs for 141T | 70 | 712440 | Relief valve with washer |
| 39 | 609834 | Strap for 176T - has no fittings | 71 | 503490 | O ring for filter barrel |
| 39 | 620130 | Strap 142T/172RT not for hook | 72 | 00-349V | Nozzle sealing washer |
| 40 | 604530 | Strap 142T/172RT - for hook | 73 | 538950 | O ring for adjustable nozzle |

SEAL KITS, REPAIR KITS & ASSEMBLIES

| Description | Part No. | Key numbers included in item |
|------------------------------------|----------------|---|
| Complete Seal Kit | 951860 | 20, 58, 59, 60, 61, 63, 66, 68, 69, 71, 72, 73. |
| Pump Group | | |
| Piston rod assembly complete | 710260V | 1, 2, 3, 4, 5, 7, 8, 9, 58. |
| Piston end components | 706490V | 5, 7, 8, 9, 58. |
| Pump barrel with footvalve | 721160 | 11, 13, 14, 59, 60. |
| Footvalve components..... | 721180 | 13, 14, 60. |
| Pump assembly complete..... | 712070 | 1, 2, 3, 4, 5, 7, 8, 9, 11, 13, 14, 58, 59, 60. |
| Trigger Valve Group | | |
| Valve spindle c/w O rings..... | 711790 | 66, 67. |
| Trigger Valve complete | 712040 | 29, 30, 34, 36, 43, 44, 46, 47, 61, 66, 67, 68, 69, 71. |
| Hose Group | | |
| Hose complete with ends..... | 00-605/OR..... | 20, 26, 27, 28, 43. |
| Spray Lance | | |
| Lance tube with washer | 701310V | 15, 61. |