

Makita®

GB	Demolition Hammer	Instruction Manual
F	Burineur	Manuel d'instructions
D	Meißelhammer	Betriebsanleitung
I	Martello demolitore	Istruzioni per l'uso
NL	Breekhamer	Gebruiksaanwijzing
E	Martillo demoedor	Manual de instrucciones
P	Martelo demolidor	Manual de instruções
DK	Opbrydningshammer	Brugsanvisning
S	Mejselhammare	Bruksanvisning
N	Meiselhammer	Bruksanvisning
SF	Purkuvasara	Käyttöohje
GR	Σφυρί κατεδάφισης	Οδηγίες χρήσεως

HM1200
HM1200B
HM1200K

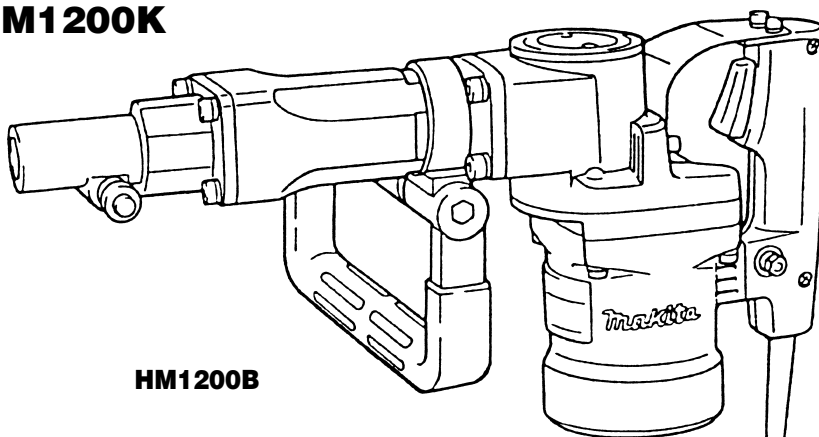

HM1200B



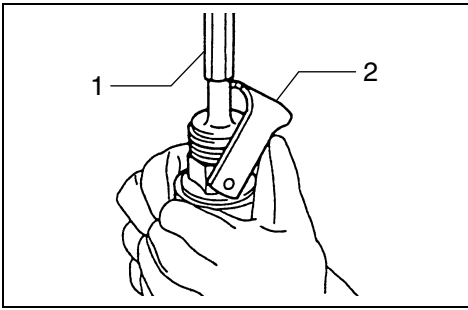

1

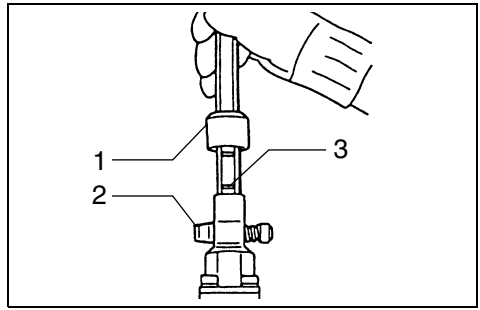

2

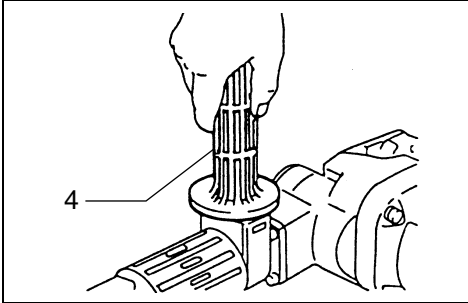

3

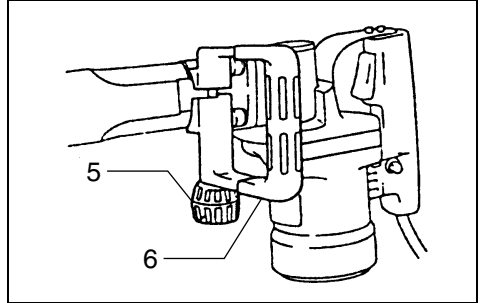

4

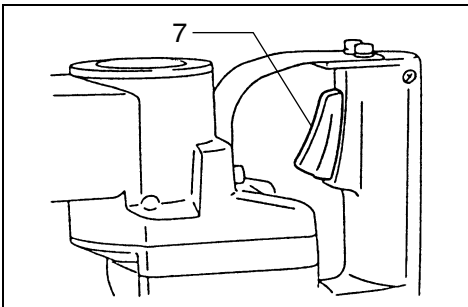

5

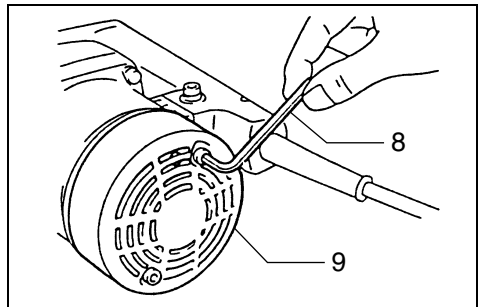

6

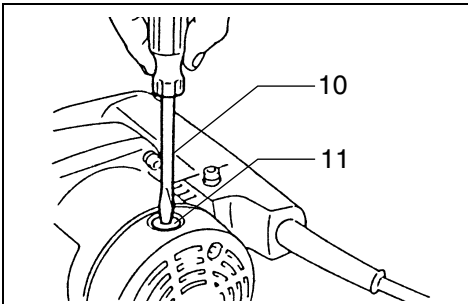

7

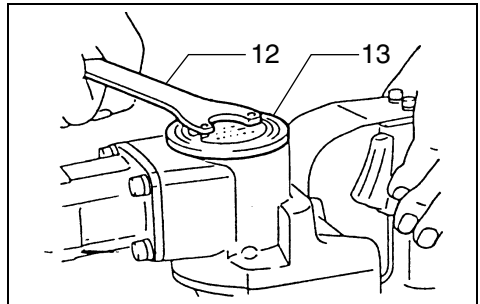

8

Symbols

The following show the symbols used for the tool. Be sure that you understand their meaning before use.

Symboles

Nous donnons ci-dessous les symboles utilisés pour l'outil. Assurez-vous que vous en avez bien compris la signification avant d'utiliser l'outil.

Symbole

Die folgenden Symbole werden für die Maschine verwendet. Machen Sie sich vor der Benutzung unbedingt mit ihrer Bedeutung vertraut.

Simboli

Per questo utensile vengono usati i simboli seguenti. Bisogna capire il loro significato prima di usare l'utensile.

Symbolen

Voor dit gereedschap worden de volgende symbolen gebruikt. Zorg ervoor dat u de betekenis van deze symbolen begrijpt alvorens het gereedschap te gebruiken.

Símbolos

A continuación se muestran los símbolos utilizados con esta herramienta. Asegúrese de que entienda su significado antes de usarla.

Símbolos

O seguinte mostra os símbolos utilizados para a ferramenta. Certifique-se de que compreende o seu significado antes da utilização.

Symboler

Nedenstående symboler er anvendt i forbindelse med denne maskine. Vær sikker på, at De har forstået symbolernes betydning, før maskinen anvendes.

Symboler

Det följande visar de symboler som används för den här maskinen. Se noga till att du förstår deras innebörd innan maskinen används.

Symbolene

Følgende viser de symbolene som brukes for maskinen. Det er viktig å forstå betydningen av disse før maskinen tas i bruk.

Symbolit

Alla on esitetty koneessa käytetyt symbolit. Opettele näiden merkitys, ennen kuin käytät konetta.

Σύμβολα

Τα ακόλουθα δείχνουν τα σύμβολα που χρησιμοποιούνται για το μηχάνημα. Βεβαιωθείτε ότι καταλαβαίνετε τη σημασία τους πριν από τη χρήση.



- | | |
|--|---|
| <input type="checkbox"/> Read instruction manual. | <input type="checkbox"/> Leia o manual de instruções. |
| <input type="checkbox"/> Lire le mode d'emploi. | <input type="checkbox"/> Læs brugsanvisningen. |
| <input type="checkbox"/> Bitte Betriebsanleitung lesen. | <input type="checkbox"/> Läs bruksanvisningen. |
| <input type="checkbox"/> Leggete il manuale di istruzioni. | <input type="checkbox"/> Les bruksanvisningen. |
| <input type="checkbox"/> Lees de gebruiksaanwijzing. | <input type="checkbox"/> Katso käyttöohjeita. |
| <input type="checkbox"/> Lea el manual de instrucciones. | <input type="checkbox"/> Διαβάστε τις οδηγίες χρήσης. |



- | | |
|---|--|
| <input type="checkbox"/> DOUBLE INSULATION | <input type="checkbox"/> DUPLO ISOLAMENTO |
| <input type="checkbox"/> DOUBLE ISOLATION | <input type="checkbox"/> DOBBELT ISOLATION |
| <input type="checkbox"/> DOPPELT SCHUTZISOLIERT | <input type="checkbox"/> DUBBEL ISOLERING |
| <input type="checkbox"/> DOPPIO ISOLAMENTO | <input type="checkbox"/> DOBBEL ISOLERING |
| <input type="checkbox"/> DUBBELE ISOLATIE | <input type="checkbox"/> KAKSINKERTAINEN ERISTYS |
| <input type="checkbox"/> DOBLE AISLAMIENTO | <input type="checkbox"/> ΔΙΠΛΗ ΜΟΝΩΣΗ |

Explanation of general view

1 Bull point	6 Side handle	11 Brush holder cap
2 Tool retainer	7 Switch trigger	12 Lock nut wrench
3 Notched portion	8 Hex wrench	13 Crank cap
4 Side grip	9 Rear cover	
5 Clamp nut	10 Screwdriver	

SPECIFICATIONS

Model	HM1200	HM1200B	HM1200K
Blows per minute.....	2,000	2,000	2,000
Overall length.....	480 mm	490 mm	490 mm
Net weight.....	8.3 kg	9.4 kg	9.1 kg

- Due to our continuing programme of research and development, the specifications herein are subject to change without notice.
- Note: Specifications may differ from country to country.

Power supply

The tool should be connected only to a power supply of the same voltage as indicated on the nameplate, and can be operated on single-phase AC/DC supply. They are double-insulated in accordance with European Standard and can, therefore, also be used from sockets without earth wire.

Safety hints

For your own safety, please refer to enclosed safety instructions.

ADDITIONAL SAFETY RULES

1. **Wear a hard hat (safety helmet), safety glasses and/or face shield. It is also highly recommended that you wear a dust mask, ear protectors and thickly padded gloves.**
2. **Be sure the bit is secured in place before operation.**
3. **Under normal operation, the tool is designed to produce vibration. The screws can come loose easily, causing a breakdown or accident. Check tightness of screws carefully before operation.**
4. **In cold weather or when the tool has not been used for a long time, let the tool warm up for several minutes by operating it under no load. This will loosen up the lubrication. Without proper warm-up, hammering operation is difficult.**
5. **Always be sure you have a firm footing. Be sure no one is below when using the tool in high locations.**
6. **Hold the tool firmly with both hands.**
7. **Keep hands away from moving parts.**
8. **Do not leave the tool running. Operate the tool only when hand-held.**
9. **Do not point the tool at any one in the area when operating. The bit could fly out and injure someone seriously.**
10. **When chipping into walls, floors or wherever "live" electrical wires may be encountered, DO NOT TOUCH ANY METAL PARTS OF THE TOOL! Hold the tool by the insulated grasping surfaces to prevent electric shock if you chip into a "live" wire.**
11. **Do not touch the bit or parts close to the bit immediately after operation; they may be extremely hot and could burn your skin.**

SAVE THESE INSTRUCTIONS.

OPERATING INSTRUCTIONS

Installing or removing bull point or other bits (cold chisel, etc.)

Important:

Always be sure that the tool is switched off and unplugged before installing or removing the bit.

For HM1200 (Fig. 1)

Pivot the tool retainer to the side. (If it is difficult to move the tool retainer with your thumbs, tap it with a hammer.) Insert the bit into the tool barrel as far as it will go. Return the tool retainer to its original position to secure the bit.

To remove the bit, follow the installation procedure in reverse.

For HM1200B & HM1200K (Fig. 2)

Pull out and turn the tool retainer 180 degrees (1/2 turn). Then insert the bit into the tool holder with the notched portion on the bit facing back toward the tool retainer. Then pull out and turn back the tool retainer 180 degrees to secure the bit. Try to pull the bit out of the tool holder to make sure the retained bit before use.

CAUTION:

Never use B-type shank bits. They can cause damage to the tool. (For HM1200B)

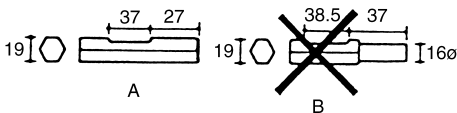

Side grip/Side handle (auxiliary handle)

For HM1200 (Standard type) (Fig. 3)

The side grip swings around to either side, allowing easy handling of the tool in any position. Loosen the side grip by turning it counterclockwise, swing it to the desired position and then tighten it by turning clockwise.

For HM1200 (European type), HM1200B & HM1200K (Fig. 4)

The side handle swings around 360° on the vertical as well as back and forth on the horizontal. Turn the clamp nut clockwise to secure the handle in the desired position.

Switch action (Fig. 5)

CAUTION:

- Before plugging in the tool, always check to see that the switch trigger actuates properly and returns to the "OFF" position when released.
- Do not tape, tie or otherwise secure the trigger in the "ON" position.

To start the tool, simply pull the trigger. Release the trigger to stop.

Chipping / Scaling / Demolition

Hold the tool firmly with both hands. Turn the tool on and apply slight pressure on the tool so that the tool will not bounce around, uncontrolled. Pressing very hard on the tool will not increase the efficiency.

MAINTENANCE

CAUTION:

Always be sure that the tool is switched off and unplugged before carrying out any work on the tool.

Replacement of carbon brushes (Fig. 6 & 7)

Whenever carbon brushes must be replaced, they cut out the tool automatically. When this occurs, replace both carbon brushes at the same time. Use only identical carbon brushes.

Lubrication (Fig. 8)

This tool requires no hourly or daily lubrication because it has a grease-packed lubrication system. Lubricate the tool every time the carbon brushes are replaced.

Run the tool for several minutes to warm it up. Switch off and unplug the tool. Remove the crank cap using a Makita lock nut wrench 35 (optional accessory). Rest the tool on the table with the bit end pointing upwards. This will allow the old grease to collect inside the crank housing. Wipe out the old grease inside and replace with a fresh grease (30 g). Use only Makita genuine grease (optional accessory). Filling with more than the specified amount of grease (approx. 30 g) can cause faulty hammering action or tool failure. Fill only with the specified amount of grease. Reinstall the crank cap and tighten with the lock nut wrench. Do not tighten the crank cap excessively. It is made of resin and is subject to breakage.

To maintain product safety and reliability, repairs, maintenance or adjustment should be carried out by a Makita Authorized Service Centre.