



Flymo®



XL500

EN	Operator's manual	6-15
DA	Brugsanvisning	16-25
DE	Bedienungsanweisung	26-37
ES	Manual de usuario	38-48
FI	Käyttöohje	49-58
FR	Manuel d'utilisation	59-69
IT	Manuale dell'operatore	70-80
NL	Gebbruksaanwijzing	81-91
NO	Bruksanvisning	92-101
PT	Manual do utilizador	102-112
SV	Bruksanvisning	113-122

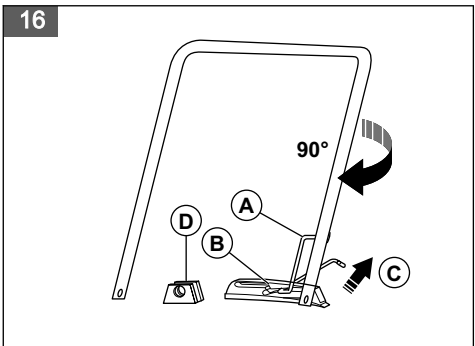
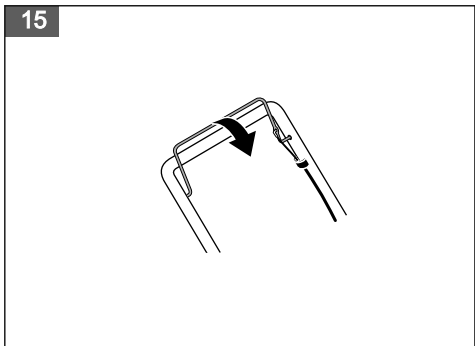
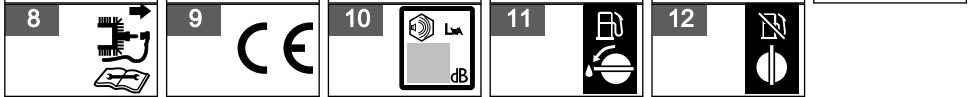
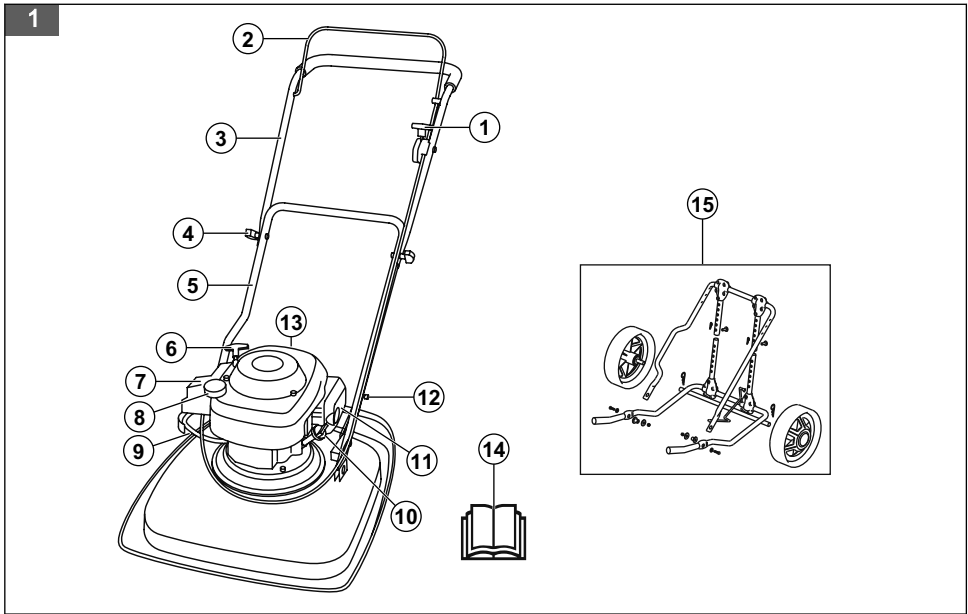

17

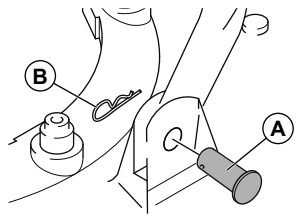

18

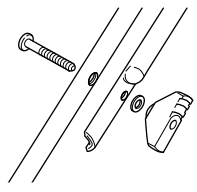

19

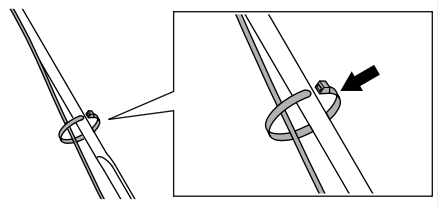

20

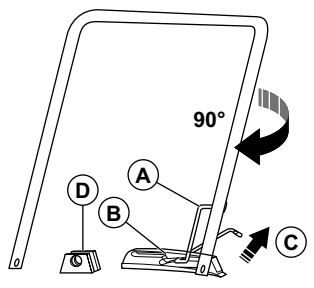

21

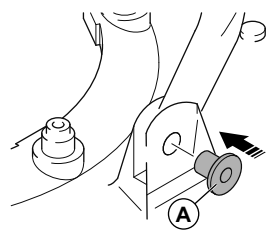

22

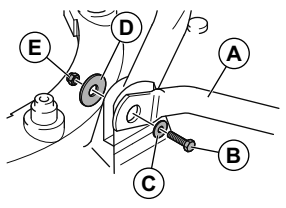

23

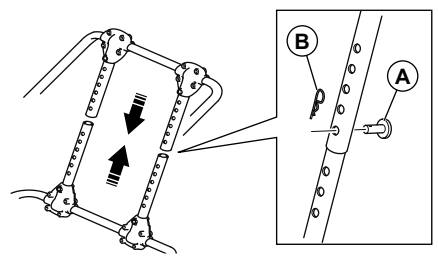

24

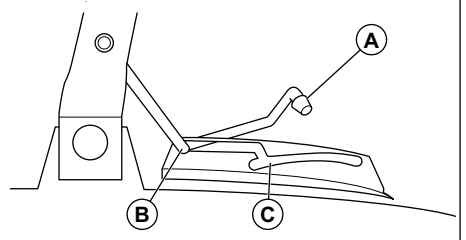

25

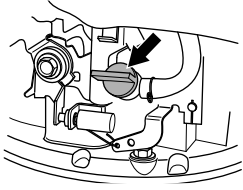

26

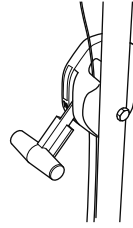

27

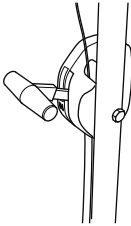

28



29

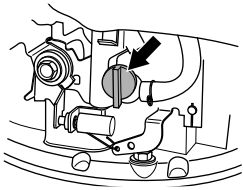

30

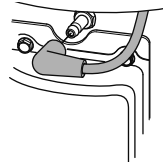

31

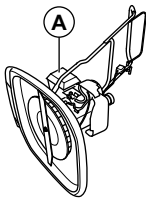

32

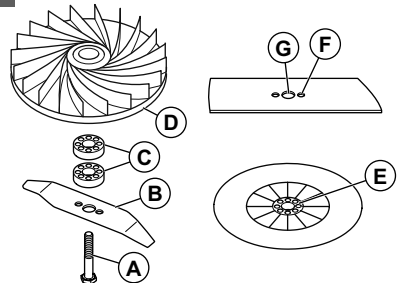

33

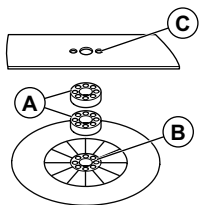

34

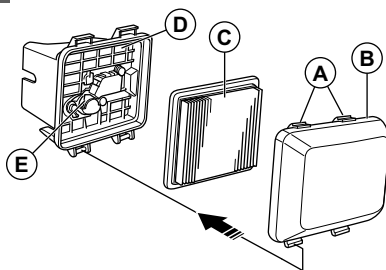

35

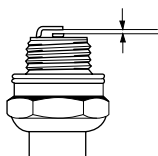

Contents

Introduction	6	Maintenance	10
Safety	7	Transportation, storage and disposal	13
Assembly	9	Technical data	13
Operation	9	EC Declaration of Conformity	15

Introduction

Product description

The product is a pedestrian-controlled rotary lawn mower. It floats on a cushion of air which makes it easy to cut grass in all areas of the lawn.

Product overview

(Fig. 1)

1. Choke control
2. Engine brake handle
3. Upper handle
4. Handle knob
5. Lower handle
6. Starter rope handle
7. Air filter
8. Fuel tank
9. Fuel valve
10. Oil cap
11. Muffler
12. Hook for adjustment of handle position
13. Spark plug
14. Operator's manual
15. Transport wheels (accessory)

Symbols on the product

(Fig. 2) **WARNING:** Careless or incorrect use can result in injury or death to the operator or bystanders.

(Fig. 3) Please read the operator's manual carefully and make sure that you understand the instructions before use.

(Fig. 4) Warning: rotating blade. Keep hands and feet clear.

(Fig. 5) Warning: rotating parts. Keep hands and feet clear.

(Fig. 6) Look out for thrown objects and ricochets.

(Fig. 7) Keep persons and animals at a safe distance from the work area.

(Fig. 8) Stop the engine and remove the ignition cable before repairs or maintenance.

Intended use

Use the product to cut grass in larger private gardens or public lawns. Can be used on slopes of maximum 45°. Do not use the product for other tasks.

(Fig. 9) This product is in accordance with applicable EC directives.

(Fig. 10) Noise emission to the environment according to the European Community's Directive. The product's emission is specified in the Technical data chapter and on the label.

(Fig. 11) Fuel valve open.

(Fig. 12) Fuel valve closed.

(Fig. 13) The exhaust fumes from the engine contain carbon monoxide, an odourless, poisonous and very dangerous gas. Do not run the product indoors or in closed spaces.

(Fig. 14) Risk of fire. Always stop the engine before refueling.

Note: Other symbols/decals on the product refer to certification requirements for other commercial areas.

Product liability

As referred to in the product liability laws, we are not liable for damages that our product causes if:

- the product is incorrectly repaired.
- the product is repaired with parts that are not from the manufacturer or not approved by the manufacturer.
- the product has an accessory that is not from the manufacturer or not approved by the manufacturer.
- the product is not repaired at an approved service center or by an approved authority.

Safety

Safety definitions

Warnings, cautions and notes are used to point out specially important parts of the manual.



WARNING: Used if there is a risk of injury or death for the operator or bystanders if the instructions in the manual are not obeyed.



CAUTION: Used if there is a risk of damage to the product, other materials or the adjacent area if the instructions in the manual are not obeyed.

Note: Used to give more information that is necessary in a given situation.

General safety instructions



WARNING: Read the warning instructions that follow before you use the product.

- This product is dangerous if used incorrectly or if you are not careful. Injury or death can occur if you do not obey the safety instructions.
- This product produces an electromagnetic field during operation. This field may under some circumstances interfere with active or passive medical implants. To reduce the risk of serious or fatal injury we recommend persons with medical implants to consult their physician and the medical implant manufacturer before operating this product.
- Always be careful and use your common sense. If you are not sure how to operate the product in a special situation, stop and speak to your Flymo dealer before you continue.
- Keep in mind that the operator will be held responsible for accidents that involve other persons or their property.
- Keep the product clean. Make sure that you can clearly read signs and decals.
- Do not let a person use the product unless you make sure that they read and understand the contents of the operator's manual.
- Do not let a child operate the product.
- Do not let a person, without knowledge of the instructions, operate the product.
- Always monitor a person, with decreased physical capacity or mental capacity, that uses the product. A responsible adult must be there at all times.
- Do not use the product if you are tired, ill, or under the influence of alcohol, drugs or medicine. This has a negative effect on your vision, alertness, coordination and judgment.

- Do not use the product if it is defective.
- Do not change this product or use it if it is possible that it has been changed by others.

Work area safety



WARNING: Read the warning instructions that follow before you use the product.

- Remove branches, twigs, stones and other loose objects from the work area before you operate the product.
- Objects that hit against the cutting equipment can eject and cause damage to persons and objects. Keep bystanders and animals at a safe distance from the product.
- Do not use the product in fog, rain, strong winds, cold weather, risk of lightning or other bad weather conditions. To use the product in bad weather or in wet locations can have a negative effect on your alertness. Bad weather can cause dangerous work conditions.
- Look out for persons, objects and situations that can prevent safe operation of the product.
- Look out for roots, stones, twigs, pits, ditches and other obstacles. Long grass can prevent a clear view.
- To cut grass on slopes can be dangerous. Do not use the product on ground that slopes more than 45°. Do not cut grass on wet slopes.
- When you cut grass on a slope, always keep your feet on level ground and the product below you on the slope.
- Operate the product across the face of slopes. Do not move up and down.
- Be careful when you go near hidden corners and objects that prevent a clear view.

Work safety



WARNING: Read the warning instructions that follow before you use the product.

- Use this product to cut grass lawns only. It is not permitted to use it for other tasks.
- Use personal protective equipment. See *Personal protective equipment on page 8*.
- Do not start the engine in a closed space or near flammable material. The exhaust fumes from the engine are hot and can contain sparks which can start a fire.
- Do not operate the product unless the blade and all covers are attached correctly. An incorrectly attached blade can come off and cause injury.

- Make sure that the blade does not hit objects such as stones and roots. This can do damage to the blade and bend the engine shaft. A bent axle causes heavy vibration and a very high risk that the blade becomes loose.
- If the blade hits an object or if vibrations occur, stop the product immediately. Disconnect the ignition cable from the spark plug. Examine the product for damages. Repair damages or let an approved service agent do the repair.
- Do not attach the engine brake handle permanently to the handle when the engine is on.
- Put the product on a stable, flat surface and start it. Make sure that the blade does not hit the ground or other objects.
- Always stay behind the product when you operate it.
- Keep 2 hands on the handle when you operate the product. Keep your hands and feet away from the rotating blades.
- Be careful when you pull the product rearward.
- Do not lift up the product when the engine is on. If you must lift the product, first stop the engine and disconnect the spark plug cable from the spark plug.
- Do not walk rearward when you operate the product.
- Stop the engine when you move across areas without grass, for example paths made of gravel, stone and asphalt.
- Do not run with the product when the engine is on. Always walk when you operate the product.
- Do not let the product stay out of view with the engine started. Stop the engine and wait until the cutting equipment stops to rotate.

- Do a check of the safety devices regularly. If the safety devices are defective, speak to your Flymo service agent.

Cutting cover

- Examine the cutting cover to make sure that there are no damages such as cracks.

Engine brake handle

The engine brake handle stops the engine. When the engine brake handle is released, the engine stops.

To do an inspection of the engine brake, start the engine and then release the engine brake handle. If the engine does not stop in 3 seconds, let an approved Flymo service agent adjust the engine brake.

(Fig. 15)

Muffler

The muffler keeps the noise levels to a minimum and sends the exhaust fumes away from the operator.

Do not use the product if the muffler is missing or defective. A defective muffler increases the noise level and the risk of fire.

Examine the muffler regularly to make sure that it is attached correctly and not damaged.



CAUTION: The muffler becomes very hot during and after use and when the engine operates at idle speed. Be careful near flammable materials and/or fumes to prevent fire.

Safety instructions for operation

Personal protective equipment



WARNING: Read the warning instructions that follow before you use the product.

- Personal protective equipment cannot fully prevent injury but it decreases the degree of injury if an accident does occur. Let your dealer help you select the right equipment.
- Use heavy-duty slip-resistant boots or shoes. Do not use open shoes or go with bare feet.
- Use heavy, long pants.
- Use protective gloves when necessary, for example when you attach, examine or clean the cutting equipment.

Safety devices on the product



WARNING: Read the warning instructions that follow before you use the product.

- Do not use a product with defective safety devices.

Fuel safety



WARNING: Read the warning instructions that follow before you use the product.

- Do not start the product if there is fuel or engine oil on the product. Remove the unwanted fuel/oil and let the product dry.
- If you spill fuel on your clothing, change clothing immediately.
- Do not get fuel on your body, it can cause injury. If you get fuel on your body, use soap and water to remove the fuel.
- Do not start the product if the engine has a leak. Examine the engine for leaks regularly.
- Be careful with fuel. Fuel is flammable and the fumes are explosive and can cause injuries or death.
- Do not breathe in the fuel fumes, it can cause injury. Make sure that there is a sufficient airflow.
- Do not smoke near the fuel or the engine.
- Do not put warm objects near the fuel or the engine.
- Do not add the fuel when the engine is on.
- Make sure that the engine is cool before you refuel.

- Before you refuel, open the fuel tank cap slowly and release the pressure carefully.
- Do not add fuel to the engine in an indoor area. Not sufficient airflow can cause injury or death because of asphyxiation or carbon monoxide.
- Tighten the fuel tank cap fully. If the fuel tank cap is not tightened, there is a risk of fire.
- Move the product a minimum of 3 m (10 ft) from the position where you filled the tank before a start.
- Do not put too much fuel in the fuel tank.
- Before you do the maintenance on the product, stop the engine and remove the ignition cable from the spark plug.
- Use protective gloves when you do maintenance on the cutting equipment. The blade is very sharp and cuts can easily occur.
- Accessories and changes to the product that are not approved by the manufacturer, can cause serious injury or death. Do not change the product. Always use accessories that are approved by the manufacturer.
- If the maintenance is not done correctly and regularly, the risk of injury and damage to the product increases.
- Only do the maintenance as given in this owner's manual. All other servicing must be done by an approved Flymo service agent.
- Let an approved Flymo service agent do servicing on the product regularly.
- Replace damaged, worn or broken parts.

Safety instructions for maintenance



WARNING: Read the warning instructions that follow before you use the product.

- The exhaust fumes from the engine contain carbon monoxide, an odourless, poisonous and very dangerous gas. Do not start the engine indoors or in closed spaces.

Assembly

To assemble the lower handle

1. Put the hook attached to the handle (A) through the center slot (B), in the direction of the arrow (C).(Fig. 16)
2. Turn the handle clockwise 90° to put the ends of the lower handle between the brackets (D) on the cutting cover.
3. Put the clevis pins (A) through the brackets and the ends of the lower handle. Lock with the lockpins (B). (Fig. 17)

To assemble the upper handle

1. Put the lower handle in park position, see *To set the handle position on page 10*.
2. Make sure that the choke control is on the left side of the product when viewed from the rear.
3. Align the holes in the upper handle with the holes in the lower handle and attach the screws, washers and knobs.(Fig. 18)
4. Use the straps to attach the cables to the handle. (Fig. 19)



CAUTION: Make sure that the tension in the cables is not too high.

To assemble the transport wheels (accessory)

1. Put the hook attached to the handle (A) through the center slot (B), in the direction of the arrow (C).(Fig. 20)
2. Turn the handle clockwise 90° to put the ends of the lower handle between the brackets (D) on the cutting cover.
3. Put the bushing (A) through the brackets and the ends of the lower handle.(Fig. 21)
4. Attach the wheel frame (A) to the cutting deck with the screws (B), washers (C, D) and locknuts (E).(Fig. 22)
5. Put the lower extension tubes into the top extension tubes.
6. Put the clevis pins (A) through the extension tubes and lock with the lockpins (B).(Fig. 23)

Operation

Introduction



WARNING: Before you operate the product, you must read and understand the safety chapter.

Before you operate the product

1. Read the operator's manual carefully and make sure that you understand the instructions.
2. Examine the cutting equipment to make sure that it is correctly attached and adjusted. See *To examine the cutting equipment on page 11*.
3. Fill the fuel tank. See *To fill fuel on page 10*.

4. Fill the oil tank and do a check of the oil level. See *To fill and change the engine oil on page 12.*

To fill fuel

If available, use low-emission/alkylate gasoline. If low-emission/alkylate gasoline is not available, use good quality unleaded gasoline or leaded gasoline. Use gasoline with octane number not less than 90 (87 AKI) and with a maximum of 10% ethanol (E10).



CAUTION: Do not use gasoline with an octane number less than 90 RON (87 AKI). This can cause damage to the product.

1. Open the fuel tank cap slowly to release the pressure.
2. Fill slowly with a fuel can. If you spill fuel, remove it with a cloth and let remaining fuel dry off.
3. Clean the area around the fuel tank cap.
4. Tighten the fuel tank cap fully. If the fuel tank cap is not tightened, there is a risk of fire.
5. Move the product a minimum of 3 m (10 ft) from the position where you filled the tank, before a start.

To set the handle position

1. Lift the hook (A). (Fig. 24)
2. Push the hook forward to set the handle in park position (B).
3. Pull the hook rearward to set the handle in mow position (C).

To start the product

1. Make sure that the ignition cable is connected to the spark plug.
2. Set the handle in park position, see *To set the handle position on page 10.*
3. Open the fuel valve. (Fig. 25)
4. Adjust the choke control.
 - a) If the engine is cold, set the choke control to the choke position. (Fig. 26)
 - b) If the engine is warm, set the choke control to the operation position. (Fig. 27)

5. Hold the engine brake handle against the handlebar.
6. Put your right foot on the cutting cover.
7. Hold the top of the lower handle with your right hand and tilt the product.
8. Hold the starter rope handle with your right hand. (Fig. 28)
9. Slowly pull out the starter rope until you feel some resistance.
10. Pull with force to start the engine.
11. When the engine is at full speed, carefully lower the product to the ground.
12. When the engine is warm, make sure that the choke control is set to operation position.
13. Set the handle in mow position, see *To set the handle position on page 10.*



WARNING: Do not twist the starter rope around your hand.

To stop the product

- Tilt the product and release the engine brake handle.
- When the engine stops, lower the product.
- Set the handle in park position, see *To set the handle position on page 10.*
- Close the fuel valve.

To get a good result

- Always use a sharp blade. A blunt blade gives an irregular result and the cut surface of the grass becomes yellow. A sharp blade also uses less energy than a blunt blade.
- Do not cut more than $\frac{1}{3}$ of the length of the grass. Cut first with the cutting height set high. Examine the result and lower the cutting height to an applicable level. If the grass is very long, drive slowly and cut 2 times if necessary.
- Cut in different directions each time to prevent stripes in the lawn.

Maintenance

Introduction



WARNING: Before you do maintenance, you must read and understand the safety chapter.

For all servicing and repair work on the product, special training is necessary. We guarantee the availability of professional repairs and servicing. If your dealer is not a

service agent, speak to them for information about the nearest service agent.

Before you do maintenance work



WARNING: To prevent injury and damage to the product, obey these instructions when it is necessary to put the product on its side.

1. Close the fuel valve. (Fig. 29)

2. Let the engine run until it stops.
3. Disconnect the spark plug cable.(Fig. 30)
4. Tilt the product to its left side, with the air filter (A) up and the muffler down.(Fig. 31)

For maintenance identified with * see instructions in *Safety devices on the product on page 8.*

Maintenance schedule

The maintenance intervals are calculated from daily use of the product. The intervals change if the product is not used daily.

Maintenance	Daily	Weekly	Monthly
Do a general inspection	X		
Examine the oil level	X		
Clean the product	X		
Examine the cutting equipment	X		
Examine the cutting cover*	X		
Examine the engine brake handle*	X		
Examine the air filter	X		
Examine the muffler*		X	
Examine the spark plug		X	
Clean the air filter			X
Change the air filter			X
Examine the fuel system			X

To do a general inspection

- Make sure that the nuts and screws on the product are tightened.

To clean the product



WARNING: Obey the instructions in *Before you do maintenance work on page 10* before you clean below the product.



CAUTION: Do not use detergent, gasoline or solvents to clean the product. That can cause damage to plastic parts.

- Do not use a high pressure washer to clean the product.
- If you use water to clean the product, do not flush water directly on the engine.
- Use a brush to remove leaves, grass and dirt.
- Make sure that the cold air intakes are not blocked.
- Remove the fan (see *To replace the blade and fan on page 12*) and clean it with a brush.
- Clean the surface of the product with a dry cloth.

- Clean below the product with a scraper to remove the buildup of grass and waste.

To examine the cutting equipment



WARNING: To prevent accidental start remove the ignition cable from the spark plug.



WARNING: Use protective gloves when you do maintenance on the cutting equipment. The blade is very sharp and cuts can easily occur.

1. Examine the cutting equipment for damage or cracks. Always replace a damaged cutting equipment.
2. Look at the blade to see if it is damaged or blunt.

Note: It is necessary to balance the blade after it is sharpened. Let a service center sharpen, replace and balance the blade. If you hit an obstacle that causes the product to stop, replace the damaged blade. Let the service center estimate if the blade can be sharpened or must be replaced.

To replace the blade and fan



WARNING: Use heavy duty gloves. The blade is very sharp and cuts can easily occur.

1. Prepare the product for maintenance work, see *Before you do maintenance work on page 10*.
2. Hold the fan tightly and turn the blade bolt (A) counterclockwise to remove it.(Fig. 32)
3. Remove the blade (B), cutting height spacers (C) and the fan (D).
4. Examine the blade bolt and the fan for damages.
5. Put the fan back in its initial position. If you add cutting height spacers, make sure that the pins are put in the holes on the fan.
6. Attach the new blade. Make sure that the pins on the fan (E) are put in the holes (F) on the blade.
7. When you attach the new blade, point the angled ends of the blade in the direction of the ground.
8. Put the blade bolt through the center hole of the blade (G) and tighten clockwise by hand.
9. Hold the fan tightly and tighten the blade bolt with a wrench.
10. Pull the blade around by hand and make sure that it turns freely.
11. Start the product to do a test of the blade. If the blade is not correctly attached, there is vibration in the product or the cutting result is unsatisfactory.

To set the cutting height

Add cutting height spacers to decrease the cutting height. Remove the cutting height spacers to increase the cutting height.

Note: Do not use more than 2 cutting height spacers.

1. Prepare the product for maintenance work, see *Before you do maintenance work on page 10*.
2. Remove the blade bolt and the blade, see *To replace the blade and fan on page 12*.
3. Put 1 or 2 cutting height spacers (A) between the fan and the blade. Put the holes on the first cutting height spacer on the pins on the fan (B). Put the pins on the second cutting height spacer in the holes on the first cutting height spacer.(Fig. 33)
4. Put the blade on the cutting height spacer. Make sure that the pins on the cutting height spacer are put in the holes (C) on the blade.
5. Attach the blade and the blade bolt, see *To replace the blade and fan on page 12*.

To fill and change the engine oil

- For information how to fill and change the engine oil, refer to the operator's manual for the engine.

To clean the air filter



CAUTION: Do not operate the engine without an air filter attached or with a dirty air filter. This decreases the efficiency and can cause damage to the engine.

1. Press the latch tabs (A), remove the air filter cover (B) and remove the air filter (C).(Fig. 34)
2. Hit the air filter against a flat surface to make the particles fall off. You can also blow compressed air through the air filter from the clean side of the air filter.



CAUTION: Do not use a brush to remove dirt as this pushes the dirt into the air filter.

3. Clean the air filter holder (D) and the air filter cover with a moist cloth.
4. Put the air filter back in its initial position. Make sure that the air filter fully seals against the air filter holder.
5. Put the air filter cover back with the bottom tabs first.



CAUTION: Do not let dirt enter the air duct that leads to the carburetor (E).

To examine the spark plug



CAUTION: Always use the recommended spark plug type. Incorrect spark plug type can cause damage to the product.

- Examine the spark plug if the engine is low on power, is not easy to start or does not operate correctly at idle speed.
- To decrease the risk of unwanted material on the spark plug electrodes, obey these instructions:
 - a) Make sure that the idle speed is correctly adjusted.
 - b) Make sure that the fuel mixture is correct.
 - c) Make sure that the air filter is clean.
- If the spark plug is dirty, clean it and make sure that the electrode gap is correct, see *Technical data on page 13*.(Fig. 35)
- Replace the spark plug if it is necessary.

To examine the fuel system

- Examine the fuel tank cap and the seal for the fuel tank cap to make sure that there are no damages.
- Examine the fuel hose to make sure that there are no leaks. If the fuel hose is damaged, let a service agent replace it.

Transportation, storage and disposal

Transportation and storage

- For storage and transportation of the product and fuel, make sure that there are no leaks or fumes. Sparks or open flames, for example from electrical devices or boilers, can start a fire.
- Always use approved containers for storage and transportation of fuel.
- Empty the fuel tank before you put the product in storage for a long period of time. Discard the fuel at an applicable disposal location
- Safely attach the product during transportation to prevent damage and accidents.
- Keep the product in a locked area to prevent access for children or persons that are not approved.
- Keep the product in a dry and frost free area.

To prepare for storage

Prepare the product for storage at the end of the season, and before more than 30 days of storage.

1. Stop the engine and close the fuel valve.
2. Start the engine and tilt the product approximately 10 cm from the ground, in the direction of the muffler.
3. When the engine stops, release the engine brake handle.

4. Disconnect the spark plug cable.
5. Drain the fuel from the fuel tank.
6. Remove the spark plug and pour 5 ml of engine oil through the spark plug hole.
7. Pull the starter rope handle 3 times to distribute the oil in the engine.
8. Examine the spark plug, see *To examine the spark plug on page 12*. Do not connect the spark plug cable.
9. Clean the air filter, see *To clean the air filter on page 12*.
10. Examine the cutting equipment, see *To examine the cutting equipment on page 11*.
11. Clean the product, see *To clean the product on page 11*.

Disposal

- Obey the local recycling requirements and applicable regulations.
- Discard all chemicals, such as engine oil or fuel, at a service center or at an applicable disposal location.
- When the product is no longer in use, send it to a Flymo dealer or discard it at a recycling location.

Technical data

Technical data

	XL500
Engine	
Brand / Model	Honda / OHC GCV 160
Displacement, cm ³	160
Speed, rpm	3150 +0/-100
Nominal engine output, kW ¹	3.0
Spark plug gap, mm	0.75
Spark plug type	NGK BPR6ES
Fuel and lubrication system	
Fuel tank capacity, liter	0.9

¹ The power rating of the engine indicated is the average net output (at specified rpm) of a typical production engine for the engine model measured to SAE standard J1349/ISO1585. Mass production engines may differ from this value. Actual power output for the engine installed on the final product will depend on the operating speed, environmental conditions and other values.

	XL500
Engine oil	SAE 10W-30
Oil tank capacity, liter	0.5
Weight	
With empty tanks, kg	18.4
Noise emissions²	
Sound power level, measured dB (A)	96
Sound power level, guaranteed L _{WA} dB (A)	97
Sound levels³	
Sound pressure level at the operator's ear, dB (A)	84
Vibration levels, a_{hveq}⁴	
Handle, m/s ²	6.16
Cutting equipment	
Cutting height, mm	10–30
Cutting width, mm	510
Blade, article number	5119004-10

² Noise emissions in the environment measured as sound power (L_{WA}) in conformity with EC directive 2000/14/EC.

³ Noise pressure level according to ISO 5395. Reported data for noise pressure level has a typical statistical dispersion (standard deviation) of 1.2 dB (A).

⁴ Vibration level according to ISO 5395. Reported data for vibration level has a typical statistical dispersion (standard deviation) of 0.2 m/s².

EC Declaration of Conformity

EC Declaration of Conformity

Husqvarna AB, SE-561 82 Huskvarna, Sweden, tel: +46-36-146500, declares that the **lawn mower Flymo XL500** from the serial number 2017xxxxxxx and onwards, complies with the requirements of the COUNCIL'S DIRECTIVE:

- of May 17, 2006 "relating to machinery" **2006/42/EC**
- of February 26, 2014 "relating to electromagnetic compatibility" **2014/30/EU**
- of May 8, 2000 "relating to the noise emissions in the environment" **2000/14/EC**

Information relating to noise emissions, see Technical data.

The following standards have been applied:

EN ISO 5395-1, EN ISO 5395-2, EN ISO 5395-2 Amd1, EN ISO 5395-2 Amd 2, EN 55012

If not otherwise stated, the above listed standards are the latest published versions.

Notified body: **0404, RISE SMP Svensk Maskinprovning AB, Box 7035, SE-750 07 Uppsala** has issued reports regarding the assessment of conformity according to annex VI of the COUNCIL'S DIRECTIVE of May 8, 2000 "relating to the noise emissions in the environment" 2000/14/EC.

The certificate has number: 01/901/302

Huskvarna, 2017-12-14



Claes Losdal, Development Manager/Garden Products
(Authorized representative for Husqvarna AB and responsible for technical documentation)